

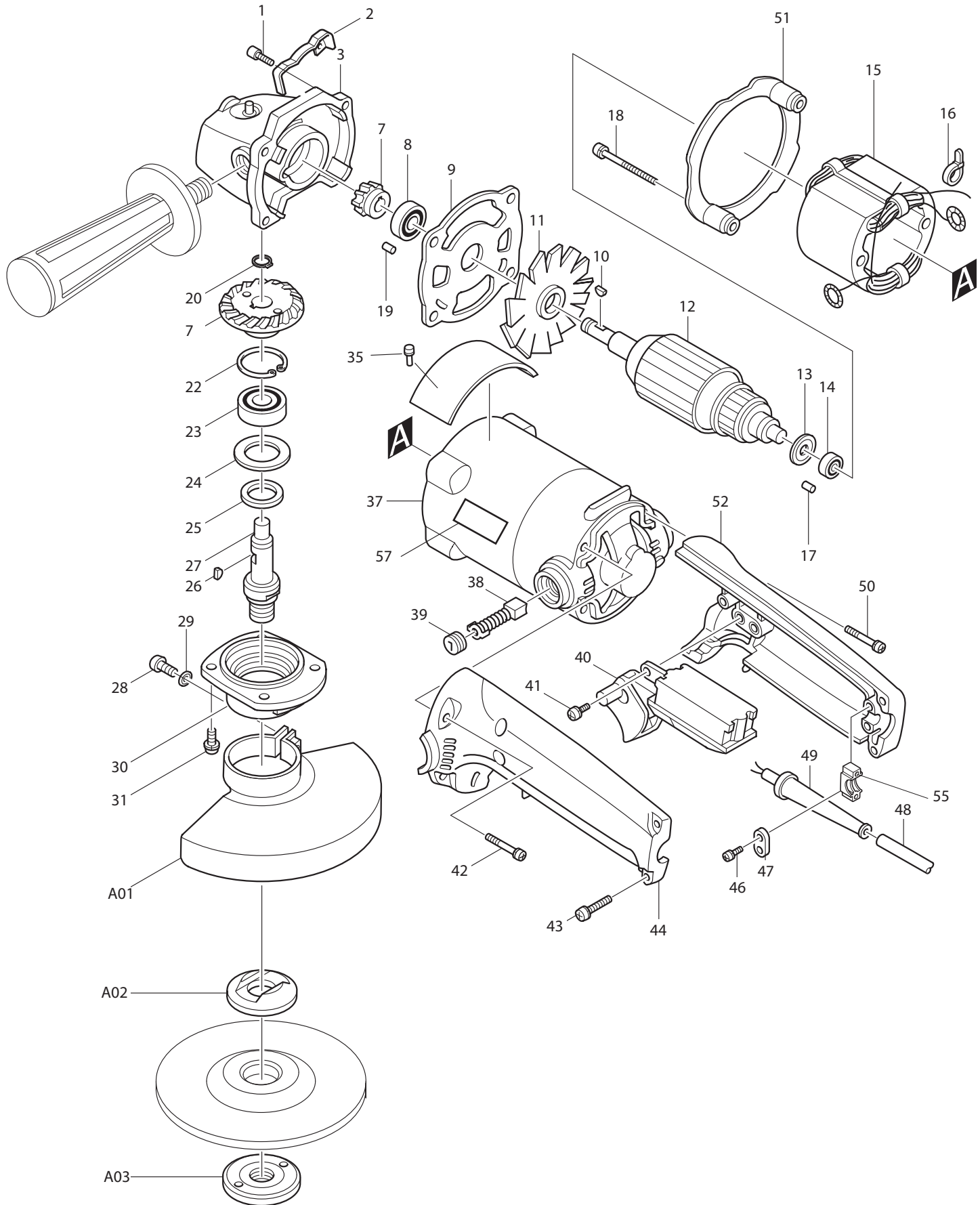

11 - 2010

9005BZ

# 5" DISC GRINDER, NO LOCK-ON BUTTON



Item No	Type	Ref	Part No	Description	Qty	Unit
1	5		266041-8	* TAPPING SCREW 5X25	4	PC.
2			341680-6	* TOOL REST (OLD)	1	PC.
3	2		159710-7	* GEAR HOUSING COMPLETE	1	PC.
		INC.	212005-0	* NEEDLE BEARING 810	1	PC.
		INC.	231464-9	* COMPRESSION SPRING 5	1	PC.
		INC.	256616-1	* PIN 5	1	PC.
		INC.	343312-1	* CUP	1	PC.
		INC.		* Item No. 19		
7	1		181737-9	SPIRAL BEVEL GEAR SET	1	SET
	2		187603-8	SPIRAL BEVEL GEAR SET	1	SET
8			211088-7	BALL BEARING 6000DDW (OLD 211061-7)	1	PC.
9			341681-4	PLATE	1	PC.
10			254002-0	WOODRUFF KEY 3	1	PC.
11			241517-6	FAN 70	1	PC.
12			516091-6	ARMATURE ASS'Y 115V	1	PC.
		INC.		Item No. 11,13,14		
13			681613-2	INSULATION WASHER	1	PC.
14			210005-4	BALL BEARING 608DDW (OLD 211033-2)	1	PC.
15	1		622516-1	FIELD ASS'Y 115V - N/L/A	1	PC.
		INC.	654019-7	RING TERMINAL	2	PC.
		INC.	654502-4	CONNECTOR P-2	2	PC.
	2		520073-2	FIELD ASS'Y 115V	1	PC.
		INC.	654019-7	RING TERMINAL	2	PC.
		INC.	654553-7	CONNECTOR 34137	2	PC.
16			687010-0	BAND	1	PC.
17			263014-2	RUBBER PIN 4	1	PC.
18	5		266029-8	* TAPPING SCREW 5X65	2	PC.
19			263002-9	RUBBER PIN 4	1	PC.
20			961052-5	RETAINING RING S-12	1	PC.
22			962151-6	RETAINING RING R-32	1	PC.
23	2		211129-9	BALL BEARING 6201DDW (OLD 211106-1)	1	PC.
24	1		253824-5	FLAT WASHER 21	1	PC.
	2		267126-3	FLAT WASHER 22	1	PC.
25			443051-4	FELT RING 20	1	PC.
26			254002-0	WOODRUFF KEY 3	1	PC.
27			321336-7	SPINDLE	1	PC.
28			251259-4	+ PAN HEAD SCREW M5X16	1	PC.
29			942101-7	SPRING WASHER (OLD)	1	PC.
30			315282-4	BEARING BOX	1	PC.
	3		266148-0	* HEX. SOCKET HEAD BOLT M4X14	4	PC.
37	5		153548-2	* MOTOR HOUSING COMPLETE	1	PC.
		INC.	643609-1	* BRUSH HOLDER 6-10	2	PC.
		INC.	810341-4	* CAUTION LABEL (Added)	1	PC.
		INC.		* Item No. 17		
38	1		191945-4	CARBON BRUSH CB-124 2PC/SET (W/O ORIGIN) - N/L/A	1	SET
	2		194982-7	CARBON BRUSH CB-124 2PC/SET (W/ ORIGIN)	1	SET
	Opt.		194975-4	AUTO CUT-OFF CARBON BRUSH CB-105 (2PCS/SET)	1	SET
39			643600-9	BRUSH HOLDER CAP 6-10	2	PC.
40			651131-4	SWITCH NO LOCK AC/DC	1	PC.
42	5		266041-8	* TAPPING SCREW 5X25	2	PC.
43			911143-2	PAN HEAD SCREW M4X22	3	PC.

Item No	Type	Ref	Part No	Description	Qty	Unit
44	2		183253-7	* HANDLE SET, NO HOLE (OLD# 183251-1)	1	SET
		INC.	421565-3	* SPONGE SHEET	1	PC.
		INC.		* Item No. 52		
	3		187582-0	* HANDLE SET, NO HOLE	1	SET
		INC.	421565-3	* SPONGE SHEET	1	PC.
		INC.		* Item No. 52		
46			265995-6	TAPPING SCREW 4X18 (OLD 265941-9)	2	PC.
47			687063-9	CORD CLAMP	1	PC.
48			664064-4	CORD W/PLUG 2P-18-2.5M, SJ	1	PC.
49			682572-3	CORD GUARD 8 (OLD 682503-2)	1	PC.
50	5		266041-8	* TAPPING SCREW 5X25	2	PC.
51			411876-4	BAFFLE PLATE	1	PC.
52	2		183253-7	* HANDLE SET, NO HOLE (OLD# 183251-1)	1	SET
		INC.	421565-3	* SPONGE SHEET	1	PC.
		INC.		* Item No. 44		
	3		187582-0	* HANDLE SET, NO HOLE	1	SET
		INC.	421565-3	* SPONGE SHEET	1	PC.
		INC.		* Item No. 52		
55			687051-6	CLAMP BASE	1	PC.
56			261039-0	URETHANE WASHER 14	3	PC.
57			819001-5	MAKITA LABEL, ENG	1	PC.
100	Opt		191728-2	URETHANE WASHER 14, 3PC/SET (OPTION) (MAKE EASY REMOVAL OF WIRE CUP BRUSH)	1	SET
D01			652014-1	P.H.SCREW M4X8 (F/ SWITCH)	4	PC.
D02	3		654113-5	* SOLDERLESS EYE TERMINAL 1.25-M4 (F/ SWITCH)	2	PC.
D03			654532-5	* TERMINAL BLOCK (ADDED)	1	PC.
<b><u>ACCESSORIES</u></b>				<b>- See catalogue or visit <a href="http://www.makita.ca">www.makita.ca</a> for more accessories information -</b>		
A01	2		135040-0	WHEEL COVER ASS'Y F/5" (OLD# 165369-0 - N/L/A)	1	PC.
		INC.		Item No. 28		
	3		135549-2	WHEEL COVER ASS'Y F/5"	1	PC.
		INC.		Item No. 28		
A02	1		224361-6	INNER FLANGE 82	1	PC.
				* For D.C.W., Multi Disc (use with TYPE1 Lock Nut 5/8-40)		
	3		224378-9	INNER FLANGE 45	1	PC.
				* For D.C.W., C.O.W., Diamond Cutter, Multi Disc (use with TYPE3 Lock Nut 5/8-45)		
	Opt.		224054-5	INNER FLANGE 40 (OPTIONAL)	1	PC.
				* For C.O.W., Diamond Cutter (use with TYPE1 Lock Nut 5/8-40)		
A03	1		224509-0	LOCK NUT 5/8-40	1	PC.
				* For D.C.W., C.O.W., Diamond Cutter, Multi Disc (use with TYPE1 Inner Flange82)		
	3		224568-4	LOCK NUT 5/8-45	1	PC.
				* For D.C.W., C.O.W., Diamond Cutter, Multi Disc (use with TYPE3 Inner Flange45)		
A04			152492-0	GRIP 36 COMPLETE	1	PC.
A05			741407-B	5" DEPRESSED CENTER WHEEL A24P	1	PC.
			D-18465	5" DEPRESSED CENTER WHEEL A24R-BF	1	PC.
A06			782412-6	LOCK NUT WRENCH 28	1	PC.
A07			743015-1	RUBBER PAD F/ 5" (F/ ABRESIVE DISC)	1	PC.
A09			193048-0	SANDING LOCK NUT 5/8-48	1	PC.
A10			122688-7	CUT-OFF WHEEL GUARD F/5"	1	PC.

**SERVICE CHANGE**

**1. SERVICE CHANGE ON MOTOR HOUSING COM., SCREW**

MCT prod

MJ prod

MCA Prod

ITEM NO.	DESCRIPTION	TYPE1	TYPE2	TYPE3	TYPE4	TYPE5
1	SCREW 5X25	911241-2 (P.H)	266041-8 (Tapping)		911241-2 (P.H)	266041-8 (Tapping)
18	SCREW 5X65	911290-9 (P.H.)	266029-8 (Tapping)		911290-9 (P.H.)	266029-8 (Tapping)
37	MOTOR HOUSING	156734-4	153455-9	153548-2	140102-1 (N/A)	153548-2
42	SCREW	911248-8 (P.H.M5X28)	266041-8 (Tapping 5X25)		911248-8 (P.H.M5X28)	266041-8 (Tapping 5X25)
50	SCREW	911248-8 (P.H.M5X28)	266041-8 (Tapping 5X25)		911248-8 (P.H.M5X28)	266041-8 (Tapping 5X25)

ABOVE PARTS ARE INTERCHANGEABLE AS A SET.

**2. SERVICE CHANGE ON GEAR HOUSING, TOOL REST, ETC.**

ITEM NO.	DESCRIPTION	TYPE1	TYPE2	TYPE3
3	GEAR HOUSING	156735-2 (N/L/A)	159710-7	
2	TOOL REST	341680-6	N/A	
31	SCREW	911121-2 (P.H.M4X14)	266034-5 (Tapping CT 4X16)	266148-0 (Hex Bolt M4X14)

ABOVE PARTS ARE INTERCHANGEABLE AS A SET.

**3. SERVICE CHANGE ON HANDLE, STRAIN RELIEF, ETC.**

(T/I# 97189)

ITEM NO.	DESCRIPTION	TYPE1	TYPE2	TYPE3
44	HANDLE (L)	183251-1 SET	183253-7 SET	187582-0 SET
52	HANDLE (R)	183251-1 SET	183253-7 SET	187582-0 SET
D02	TERMINAL	654002-4 (4PC)	654113-5 (4PC)	654113-5 (2PC)
D03	TERMINAL BLOCK	-----		654532-5

TYPE 1-5 PARTS ARE INTERCHANGEABLE AS A SET.

TYPE 5-6 ARE INTERCHANGEABLE EACH OTHER

TYPE 5

TYPE 6

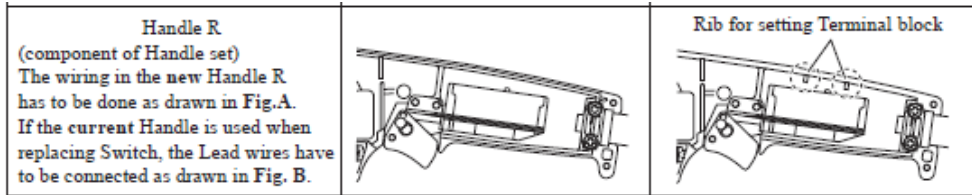

Fig.A

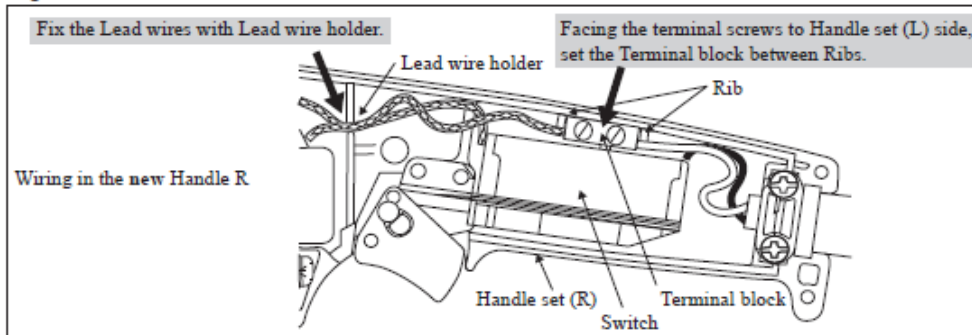
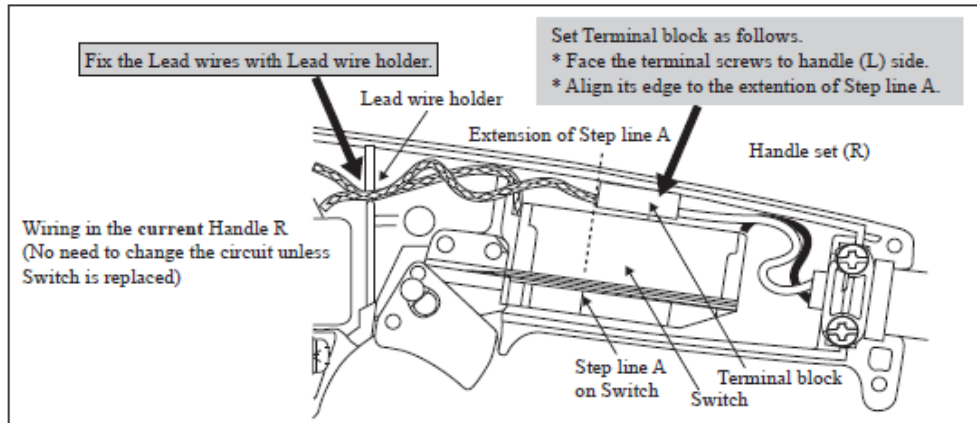

Fig.B



**SEE T/# 97189 FOR WIRING CHANGES**